

Submersible Pumps

50 Hz 6" Stainless Steel 46 m³/h Specifications

6" PUMP ENDS												
M3/h	kW	HP	Stages	Motor Size (in)*	PART NUMBERS 304 SS		PART NUMBERS 316 SS		Length (mm) - P	Weight (kg)	Discharge (in) -D	
					Model No.	Order No.	Model No.	Order No.				
46	3	5	2	4" (1)	46SR3F65-0243	97160046002	46SR3S65-0243	97161046002	593.5	13.5	3	
	3.7	5	3	4" or 6"	46SR4F65-0363	97160046003	46SR4S65-0363	97161046003	705.5	16.16	3	
	5.5	7.5	4	4" or 6"	46SR5F65-0463	97160046004	46SR5S65-0463	97161046004	819.5	18.77	3	
	7.5	10	5	4" or 6"	46SR7F65-0563	97160046005	46SR7S65-0563	97161046005	933.5	21.38	3	
	9.3	12.5	7	6"	46SR9F65-0763	97160046007	46SR9S65-0763	97161046007	1161	26.59	3	
	11	15	8	6"	46SR11F65-0863	97160046008	46SR11S65-0863	97161046008	1275	29.2	3	
	15	20	11	6"	46SR15F65-1163	97160046011	46SR15S65-1163	97161046011	1617	37.02	3	
	18.5	25	14	6"	46SR18F65-1463	97160046014	46SR18S65-1463	97161046014	1958.5	44.82	3	
	22	30	17	6"	46SR22F65-1763	97160046017	46SR22S65-1763	97161046017	2300	52.66	3	
	30	40	20	6"	46SR30F65-2063	97160046020	46SR30S65-2063	97161046020	2641.5	60.48	3	
	30	40	23	6"	46SR30F65-2363	97160046023	46SR30S65-2363	97161046023	2983	68.3	3	
	37	50	25	6"	46SR37F65-2563	97160046025	46SR37S65-2563	97161046025	3210.5	73.51	3	

* Pumps marked as 4" or 6" motor come standard for 6" motors. A 4" motor bracket adapter is required for use on a 4" motor. (Part no. 305 473 001)

(1) Pump includes 4" motor bracket adapter.

Dimensions

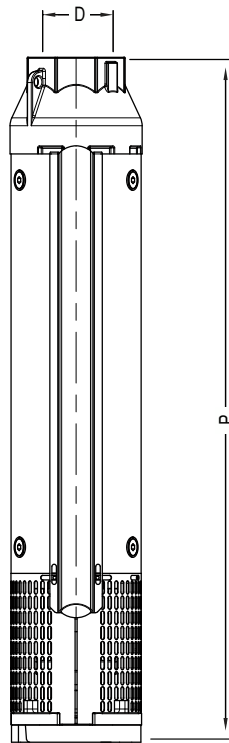

	Diameter with 1 cable cover	Diameter with 2 cable cover
Pump 6" with motor 4"	142.5	-
Pump 6" with motor 6"	143	144.5

4" Motor Adapter

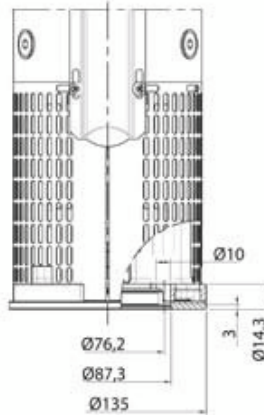

6" Motor Adapter

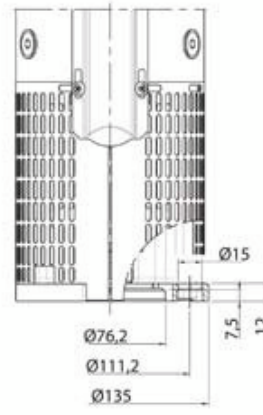

8" Motor Adapter

Part no. 305 473 002

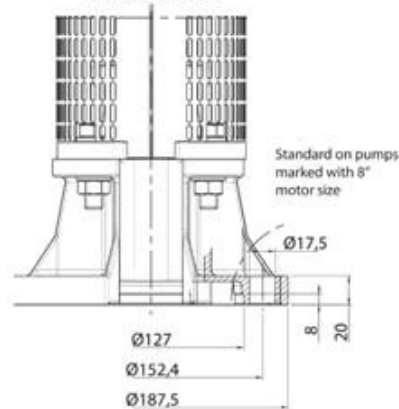

8" motor adapter kit for use on 6" pump includes bracket, shaft coupler and motor bolts

Submersible Pumps

50 Hz 6" Stainless Steel 46 m³/h Performance Curve

Performance Curves 50 Hz

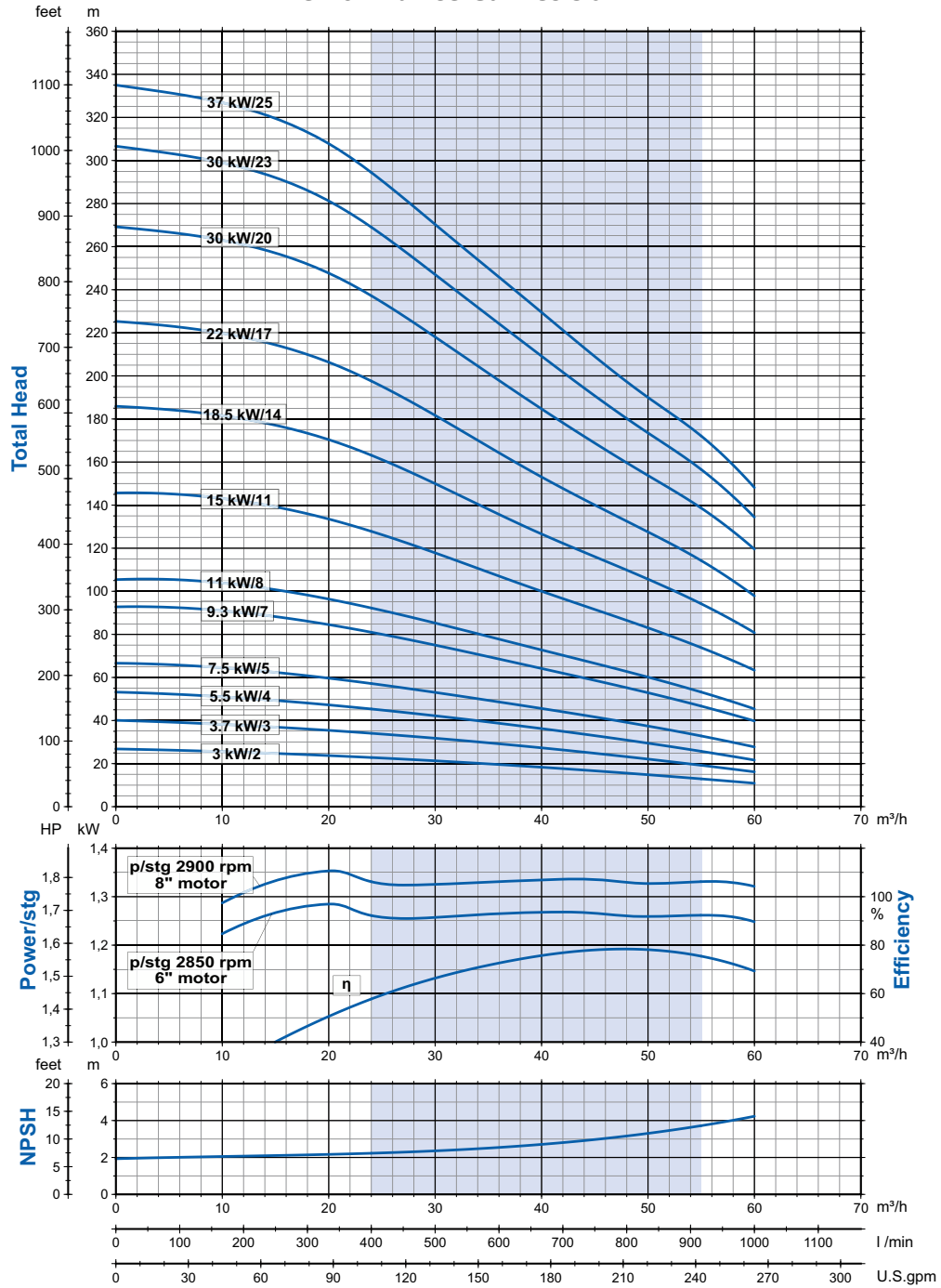

Submersible Pumps

50 Hz 6" Stainless Steel 46 m³/h Specifications

46	37	50	28	6"	46SR37F65-2863	97160046028	46SR37S65-2863	97161046028	3552	81.98	3
	45	60	30	6"	46SR45F65-3063	97160046030	46SR45S65-3063	97161046030	3779.5	87.2	3
	45	60	33	6"	46SR45F65-3363	97160046033	46SR45S65-3363	97161046033	4121	95.02	3
	55	75	34	8"	46SR55F65-3483	97160046034	46SR55S65-3483	97161046034	4335	100.83	3
	55	75	37	8"	46SR55F65-3783	97160046037	46SR55S65-3783	97161046037	4676.5	108.72	3
	55	75	40	8"	46SR55F65-4083	97160046040	46SR55S65-4083	97161046040	5018	116.61	3

Dimensions

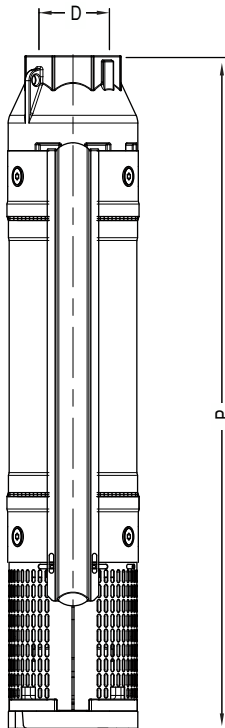

	Diameter with 1 cable cover	Diameter with 2 cable cover
Pump 6" with motor 6"	145	146.5
Pump 6" with motor 8"	190.5	190.5

6" Motor Adapter

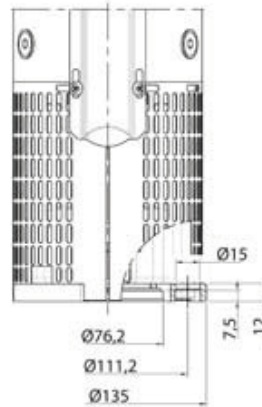

8" Motor Adapter

Part no. 305 473 002

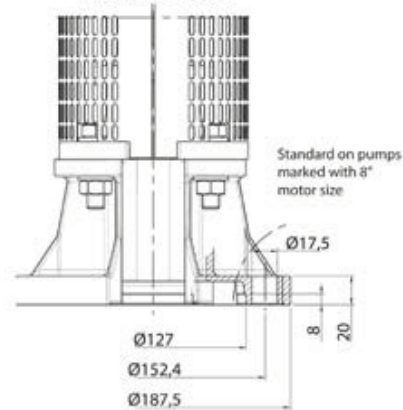

8" motor adapter kit for use on 6" pump includes bracket, shaft coupler and motor bolts

*Note: All units are in millimeters

Submersible Pumps

50 Hz 6" Stainless Steel 46 m³/h Performance Curve

Performance Curves 50 Hz

