

PW-A Series Submersible Pump

Power: 0.1 - 0.4 kW

Head: Up to 10 M

Flow: Up to 260 L/min

Outlet: 1" - 2"



Coverage of Application

1. To be used to circulate water in garden ponds
2. To be applicable to the sprinkler for vegetations of parks.
3. Watering in the garden and washing car.
4. To drain the accumulated water for basement of residence.
5. To drain the ground water.
6. To drain accumulated water for civil and architecture engineering.
7. The "R" type available to used in sea fish breeding.
8. The "C" type equipped level regulator.
9. The "F" type equipped float ball level switch.
10. The "D" type low suction capability up to 3 mm

Characteristic

1. Submersible pumps for clean water.
2. Corrosion-resistant and compact.
3. Built-in capacitor.
4. Supplied with power cable with plug
5. Motor with thermo overload protection

Specifications

1. Power supply: single-phase 50 or 60 Hz
2. Power: 100W to 400W
3. Insulation class: B
4. Protection: IP68
5. Length of cable: 4 or 5 m
10 m (Optional)
6. Delivery: up to 260 L/min
7. Head: up to 10 m
8. Temperature of pumped liquid: 4°C to +35°C

Level regulator

PW100AC / PW100ARC

ON
Water level > 20cm

OFF
Water level < 5cm

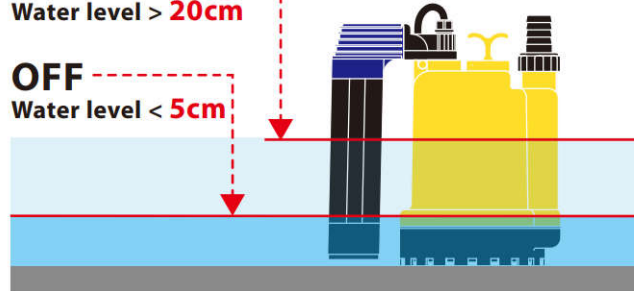

Float ball level switch

PW100AF / PW100ARF / PW250AF
PW400AF / PW400ARF

ON
+50°

OFF
-50°

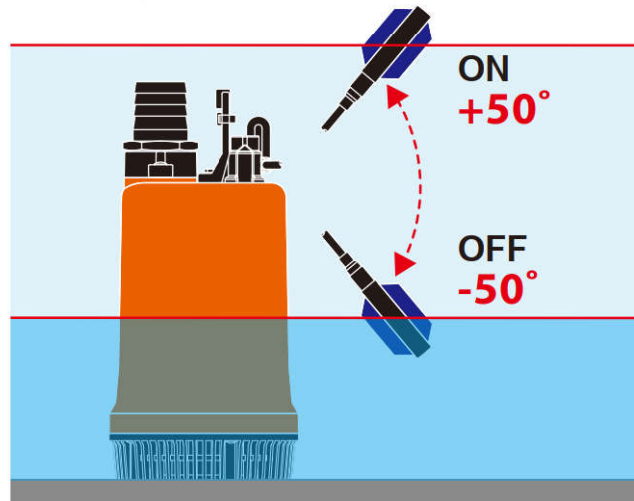

Low suction Pump

Performance curve

PW250AD / PW400AD

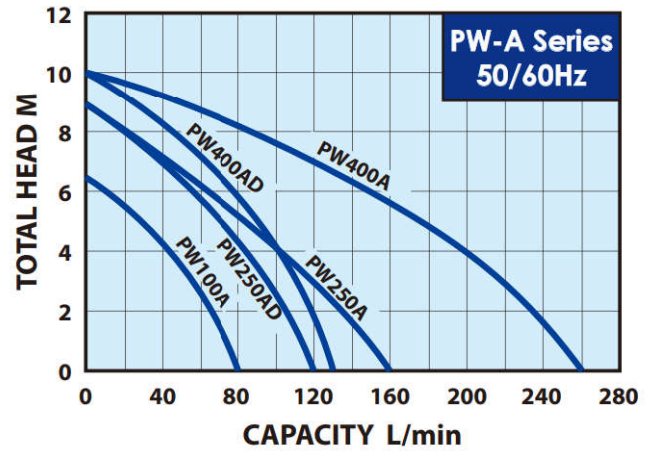
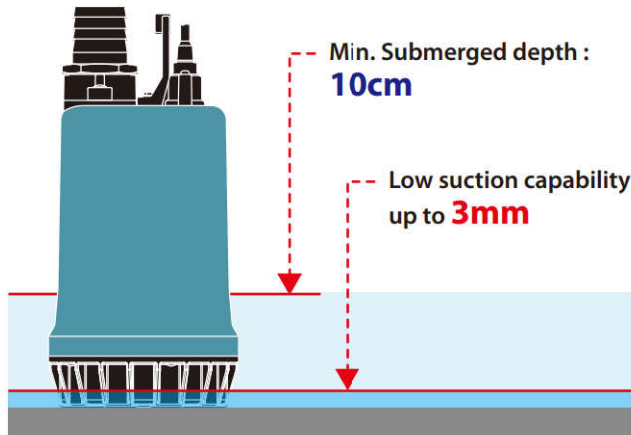

Specification

Type	Outlet Diameter In. (mm)	Output W	Cycle Hz	Volt V	Amp's A	Maximum		Dimensions L x W x H mm	Cable Wire C x mm ² x m	N.W. kg	G.W. kg	
						Head m	Capacity L/min					
PW100A	1" (25)	100	50	220 - 240	1.0	6.5	80	155 x 140 x 241	3 x 0.75 x 4	4.1	4.7	72
			60	110 220	2.0 1.0							
PW250A	1½" (32)	250	50	220 - 240	2.0	9.0	160	164 x 164 x 350	3 x 1.25 x 5	5.1	5.5	48
			60	110 220	4.0 2.0							
PW400A	2" (50)	400	50	220 - 240	3.5	10	260	183 x 183 x 382	3 x 1.25 x 5	7.9	8.3	50
			60	110 220	7.0 3.5							

Sea water pump

PW100AR	1" (25)	100	50	220 - 240	1.0	6.5	80	155 x 140 x 241	3 x 0.75 x 4	4.1	4.7	72
			60	110 220	2.0 1.0							
PW400AR	2" (50)	400	50	220 - 240	3.5	10	260	183 x 183 x 382	3 x 1.25 x 5	7.9	8.3	50
			60	110 220	7.0 3.5							

Pump with level regulator

PW100AC	1" (25)	100	50	220 - 240	1.0	6.5	80	220 x 140 x 241	3 x 0.75 x 4	4.6	5.1	48
PW100ARC			60	110 220	2.0 1.0							

Pump with float ball level switch.

PW100AF	1" (25)	100	50	220 - 240	1.0	6.5	80	155 x 140 x 241	3 x 0.75 x 4	4.3	4.9	48
			PW100ARF	60	110 220							
PW250AF	1½" (32)	250	50	220 - 240	2.0	9.0	160	164 x 164 x 350	3 x 1.25 x 5	5.3	5.7	48
			PW250ARF	60	110 220							
PW400AF	2" (50)	400	50	220 - 240	3.5	10	260	183 x 183 x 382	3 x 1.25 x 5	8.1	8.5	50
			PW400ARF	60	110 220							

Low Suction Pump (Drainage to 3 mm from floor)

PW250AD	1½" (32)	250	50	220 - 240	2.0	9	120	164 x 164 x 350	3 x 1.25 x 5	5.6	6.0	48
			60	110 220	4.0 2.0							
PW400AD	2" (50)	400	50	220 - 240	3.5	10	130	183 x 183 x 384	3 x 1.25 x 5	8.4	8.8	50
			60	110 220	7.0 3.5							