

DAVEY

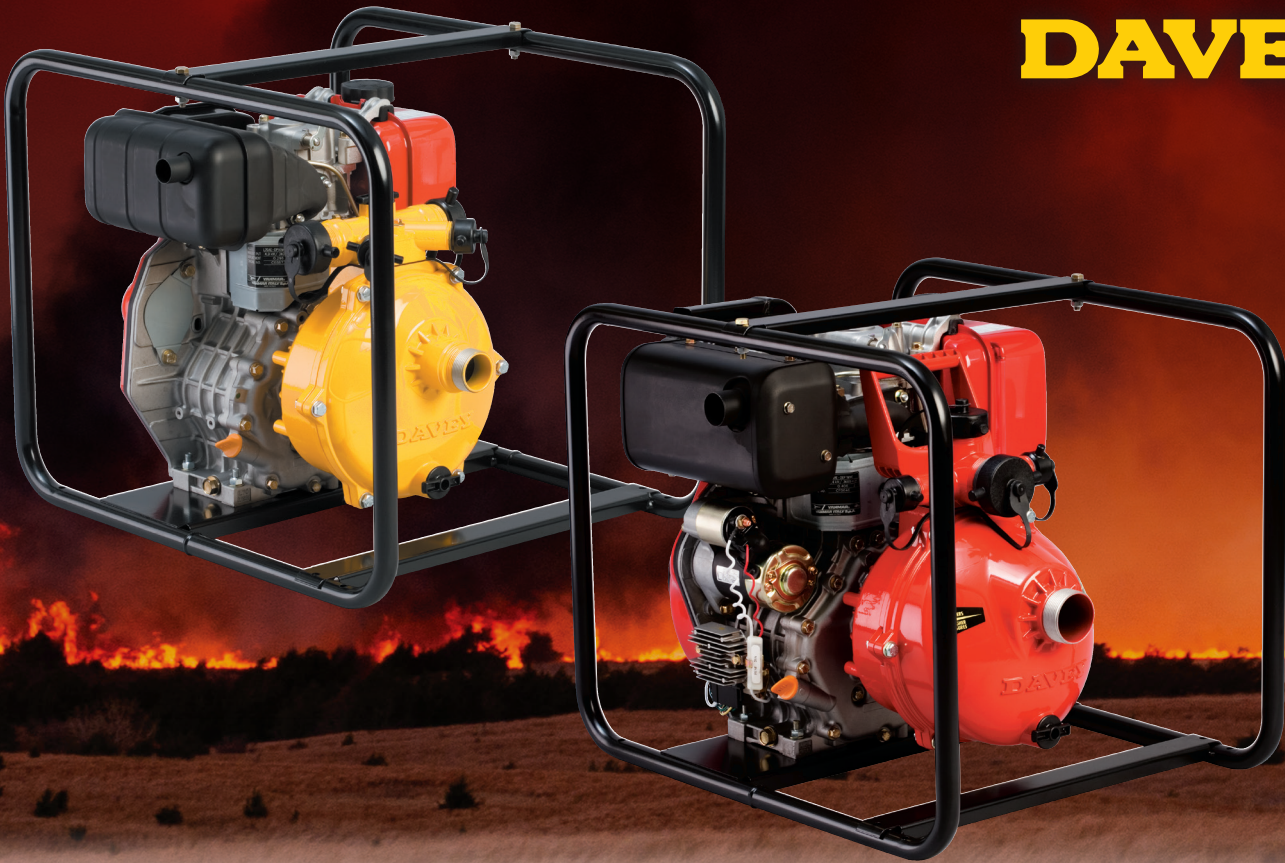

DAVEY Firefighter®

Model Number:
5170YE, 5270YE, 5210YE/HP

GUARANTEE
1 YEAR - wet end, engines
and accessories
Please consult your Davey
dealer for details.

APPLICATIONS

Ideal for firefighting, tank filling, irrigation, garden watering, water transfer and crop spraying.

ECONOMICAL DIESEL POWERED SINGLE & TWIN STAGE SELF PRIMING PUMP

FEATURES & BENEFITS

Driven by either a Yanmar L70 or Yanmar L100 diesel engine.

All models (except 5110YE) feature patented clamped impeller design to enable longer impeller life, improved performance and easier disassembly in the case of blockage.

Model 5110YE feature heavy duty sand cast impellers.

Thrust balanced impeller design to extend engine life.

Pump casing, diffusers and impellers manufactured from quality corrosion resistant marine grade aluminium for long life.

4 way discharge port for L70 equipped models and 3 way discharge for L100 equipped models providing easy installation with a choice of plumbing sizes.

Epoxy coated pump casing, exterior and interior, for added corrosion resistance.

Patented floating impeller neckrings front and back. The front neckring helps improve pumping efficiency, the back neckring helps extend seal life and dramatically reduce engine wear.

Self priming from up to 5m at 3000rpm for more versatile installation options.

Large priming and drain port with bayonet fit plugs.

Plugs have a safety retention system and are available with 1/4" tapping to accept pressure gauges or drain cocks.

All engines feature cast iron cylinder bore for long life.

All models have electric starter (battery, battery mount and leads required) and recoil starter fitted ensuring a choice of starting methods, even if the battery is flat or removed.

Viton seal and oring kit available for herbicide/ insecticide spraying.

Attractive baked enamel roll frame with anti-vibration mounts for ease of transportation and installation.

Electric Start battery requirements:

- Battery not included
- Minimum 12 volt battery required :-

L70: 24-36AH

L100: 36-45AH

Engine Driven Pumps



OPERATING LIMITS		
Model	5170YE/5270YE	5210YE/HP
Flow capacities to	800 lpm	
Maximum total head	92m	
Maximum suction lift	7m	
Maximum water temperature	50°C	
Minimum water temperature	1°C	
Minimum suction pipe size	1 1/2"	2"
Suction pipe strainer	Required	
Inlet size	1 1/2" BSP(M)	2" BSP(M)
Outlet sizes	2 x 1 1/2" BSP(M) 2 x 1" BSP(M)	1 x 2" BSP(M) 2 x 1" BSP(M)
Priming port	1 x 1 1/2" BSP(M)	

ENGINE SPECIFICATIONS		
Model	5170YE/5270YE	5210YE/HP
Engine brand	Yanmar	
Engine Model	L70	L100
Engine Type	Diesel	
Displacement (cc)	296	406
Fuel Tank (litres)	3.5	5.5
Oil Capacity (litres)	1.1	1.65
Compression Ratio	19.5:1	19.3:1
Air Filter Type	Dry element	
Spark Arrestor	No	
Approx. fuel consumption @ full load @ 3600 rpm	1.6 l/hr	2.5 l/hr
dBa @ 7m @ 3600 rpm @ full load	80.5	82.5

HYDRAULIC PERFORMANCE	
All Davey Diesel models (except 5210YE/HP) are set with governors at 3000rpm "out of box" speed. At this speed the pump will not overload the engine under a variety of continuous pumping conditions, such as:-	
5170YE Pumping fresh water Ambient temperature up to 40°C Humidity up to 50% Altitude up to 200 metres above sea level	5270YE, 5270YE/HP Pumping fresh water Ambient temperature up to 30°C Humidity up to 70% Altitude up to 400 metres above sea level
The performance curves below indicate the safe continuous pumping limits (solid curve) at a variety of speeds. The intermittent duty performance (dotted curve) is applicable ONLY for short periods.	

DIMENSIONS (mm)								
Model	A	B	C	D	E	Inlet BSP	Outlet BSP	Net Weight (kg)
5170YE 5270YE	675	545	520	224	355	1 1/2" M	2 x 1" M 2 x 1 1/2" M	43 45
5210YE/HP	675	545	520	234	365	2" M	2 x 1" M 1 x 2" M	65 66

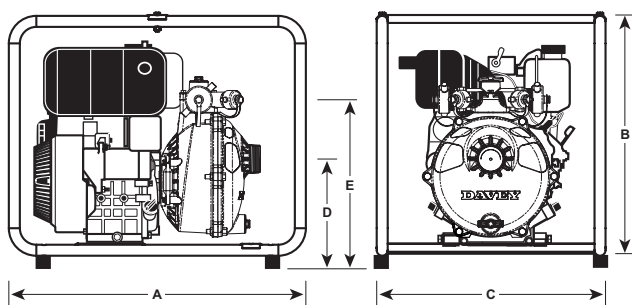

MATERIALS OF CONSTRUCTION	
PART	MATERIAL
Suction cover	Marine grade aluminium (AS605)
Diffuser	Marine grade aluminium (AS605)
Impeller	Marine grade aluminium (AS605)
Casing / yoke	Marine grade aluminium (AS605)
Mechanical seal	Carbon / ceramic
4 way discharge	Marine grade aluminium (AS605)
Casing bolts	Zinc plated steel
Yoke bolts	Stainless steel
Flap valve / seal ring	Zinc body, Hytrel seal
Neck ring, priming and drain plug	Glass filled nylon
Casing, priming and drain plug o-ring	Nitrile rubber
Discharge gasket	Hytrel
Paint finish	Baked polyester powder coat

USAGE GUIDE
These Diesel powered pumps are intended for portable applications. The use of long range fuel tanks is discouraged, since proper maintenance schedules are unlikely to be followed when such tanks are installed. Care must be taken to ensure the operator is fully briefed on safe operation of these pump units, especially in regards to the daily engine maintenance requirements.

SELF PRIMING PERFORMANCE		
Self priming pumps work best when operated at higher speeds. The Yanmar diesel engines are set at 3000rpm "out of box" (except 5210YE/HP). They may be adjusted to 3600rpm, but care must be taken regarding overloading at this speed. In normal operating conditions, where the pump is able to evacuate the air properly, the self priming times through a 40mm suction hose will be:-		
Depth (metres)	Speed (rpm)	Time (seconds)
1	3000	30
1	3600	20
2	3000	90
2	3600	50
3	3000	110
3	3600	80

AUTOMATIC CONTROLLER OPTIONS
A number of shut down and automatic control units are available as factory fitted accessories. All ACD and ACP control units (except ACD-KS) come complete in a weatherproof metal enclosure.
Fitment of the Automatic Controllers requires removal of the fuel tank, which is re-installed onto the engine.
Auxiliary Fuel Tank - Should an auxiliary fuel tank be required, this must be installed at or above the original tank height. The tank must also be equipped with a suitable 5 micron or finer filter system. The engine will still require regular maintenance of oil and air cleaners as per the engine operation manual.
Controllers - Are supplied loose for adjacent remote mounting with pump unit.
 ACP200
ACD-KS
Now standard on all electric start engines. Allows the key starting and stopping of LN series engines - ideal for truck mounted pump units etc.
ACD-EC150TP
Engine shutdown system which includes all the features of the ACD-EC150, plus a pressure transducer for shutdown on hi/lo pump pressure.
ACP200
Automatic start/stop controller with all the protection features of the ACD-EC150TP, plus the ability to start and stop via an inbuilt time clock, or other external controls (e.g. irrigation controller, pressure switch)

HYDRAULIC PERFORMANCE

5170YE

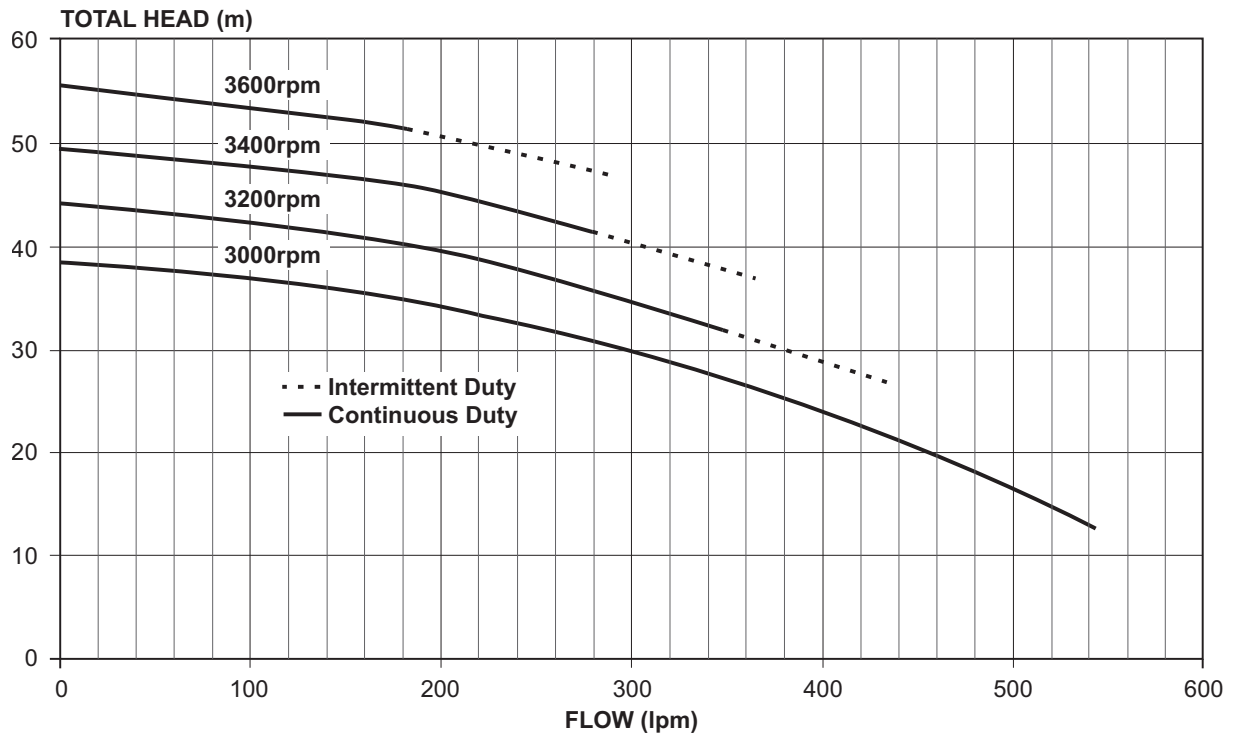

5270YE

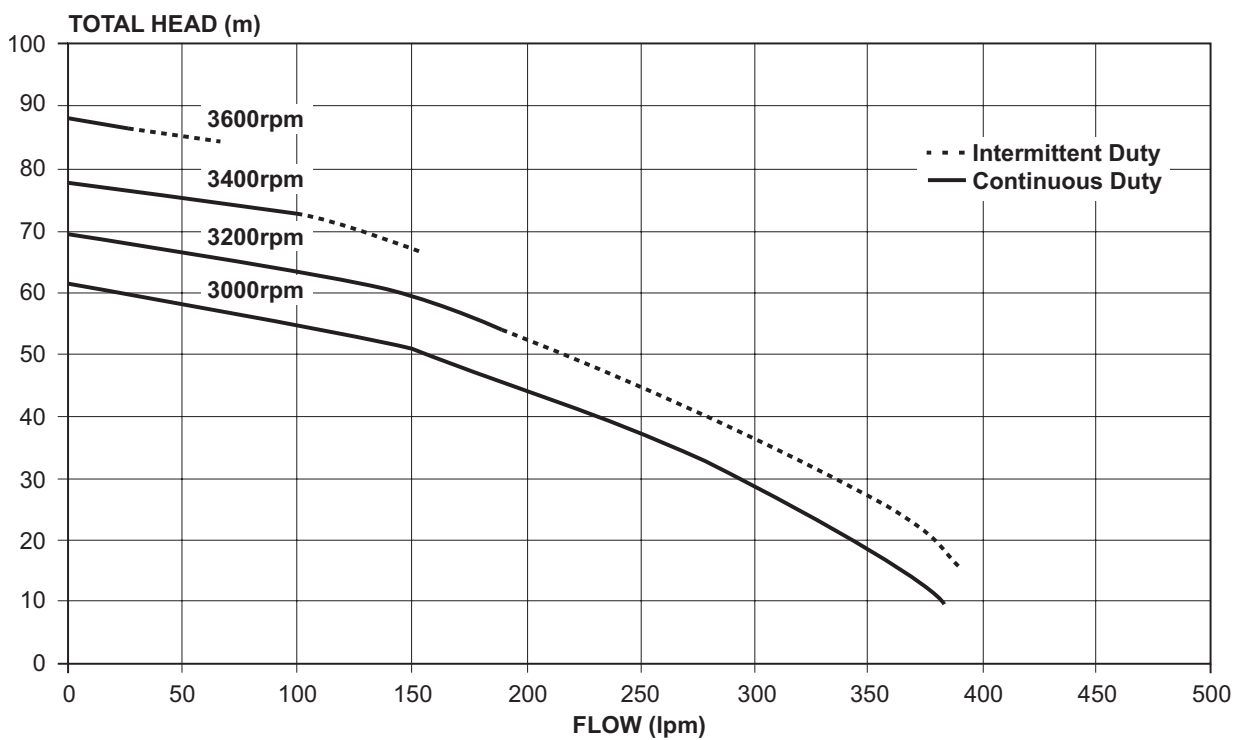

HYDRAULIC PERFORMANCE

5210YE/HP

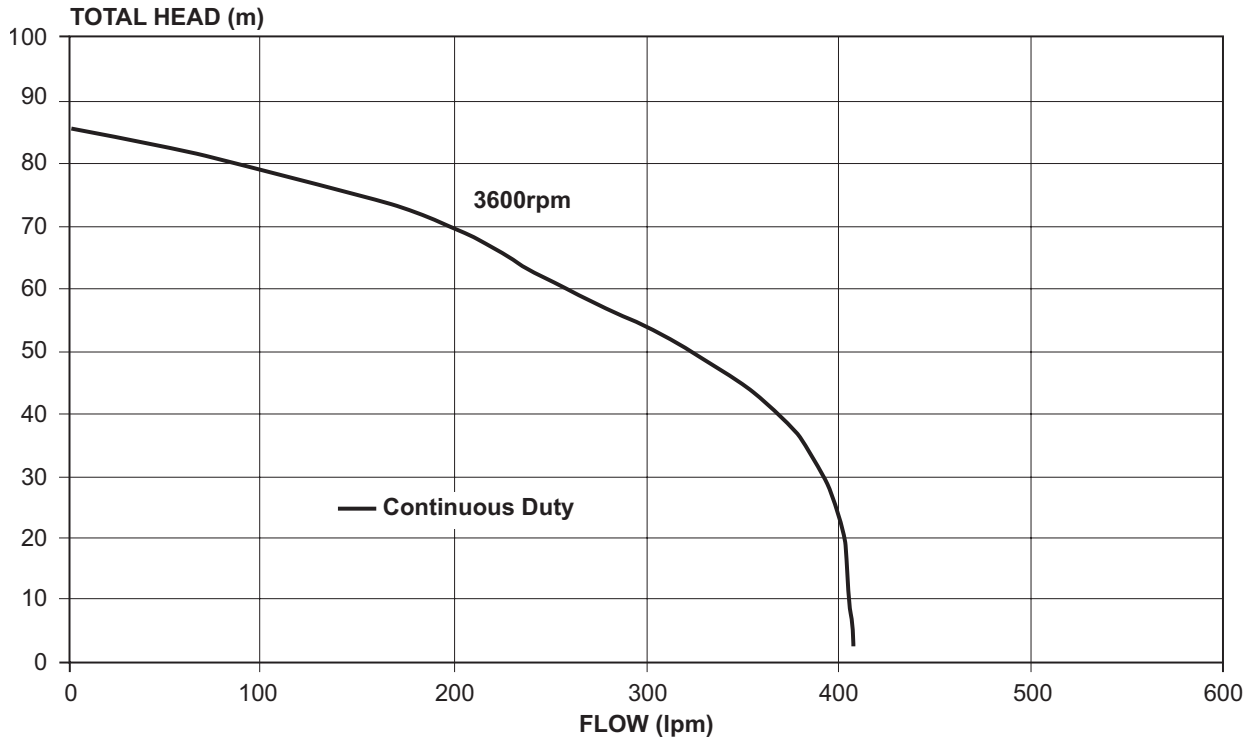

daveywater.com

This literature is not a complete guide to product usage. All images provided in this document are for illustration purposes only. Further information is available from your Davey Dealer, Davey Support Centre and from the relevant product Installation and Operating Instructions. Must be read in conjunction with the relevant product Installation and Operating Instructions and all applicable statutory requirements. Product specifications may change without notice. © Davey is a registered trademark of Davey Water Products Pty Ltd. © Davey Water Products Pty Ltd 2024.

