

# KDI 1903 TCR

## QUICK SPECIFICS

**3** Turbo common rail  
CYLINDER

**56** | **42** @ 2600 rpm  
HP | kW TIER 4 Final  
STAGE III B

**225** @ 1500 rpm  
Nm



## DATA

### DIMENSIONS (mm)

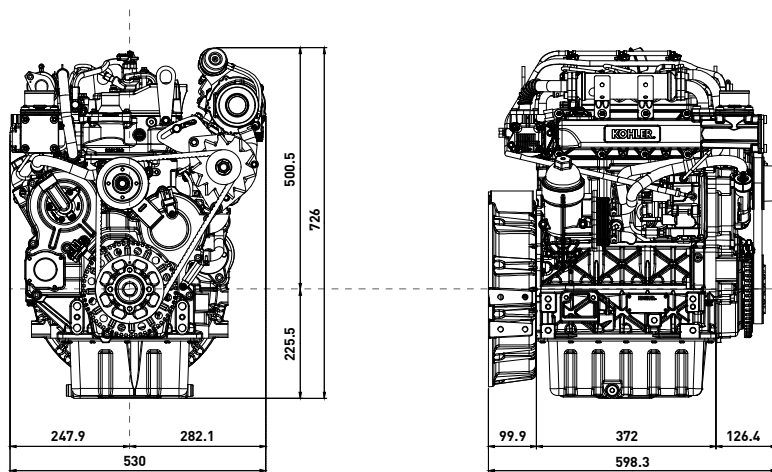

## GENSET RATINGS

	rpm	1800
NET ENGINE POWER*	Stand-by (kW)	35.0
	Prime (kW)	31.8
ELECTRICAL POWER**	Intermittent (kVA)	37.6
	Continuous (kVA)	34.2
EMISSION COMPLIANCE	Stage IIIA / Tier 4 F	
MAX. EMISSION COMPLIANCE AVAILABLE***	Tier 4 F	

\* Engine power rating ISO IFN (Stand-by) and ICXN (Prime) according to ISO 3046 and ISO 14396, after running-in period at ambient condition +25°C, relative humidity 30%, and ambient pressure 100 kPa (1 bar). Fuel specification EN590

\*\*Electrical power includes fan power absorption, typical alternator efficiency and a power factor (cos  $\phi$ ) of 0.8  
Continuous (Prime) power can be overloaded of 10% for 1 h every 12 hours operation  
Intermittent (Standby) power cannot be overloaded.

\*\*\* Possible de-rating might have to be taken in consideration to ensure emission compliance.

## PERFORMANCE CURVES (IFN-ACCORDING TO ISO 3046 AND ISO 14396)

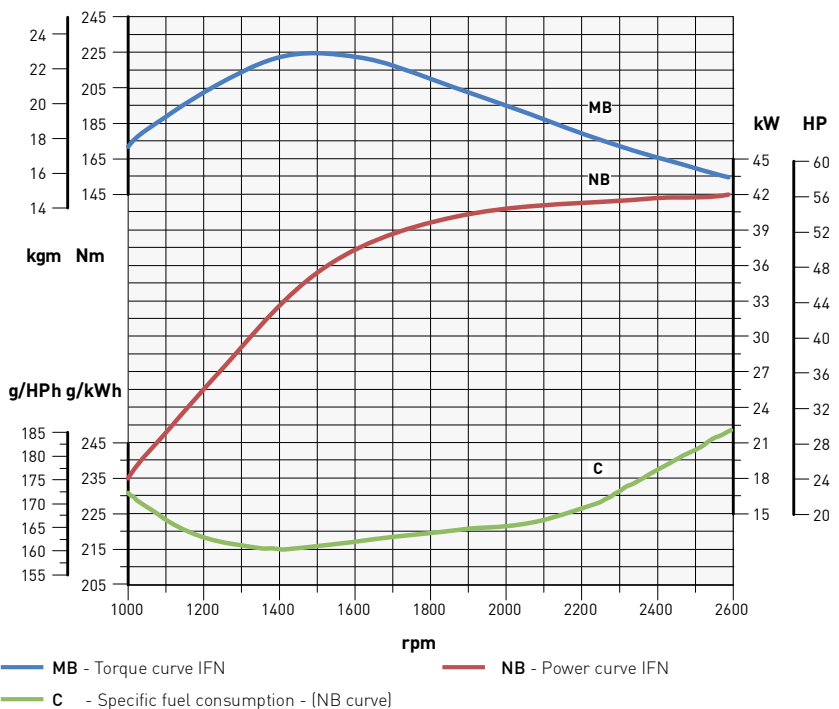

Power ratings refer to engines equipped with air filter, standard muffler, after running-in period at ambient conditions of +25°C, relative humidity 30% and 1 bar. De-rating depending on applications.

# TURBO COMMON RAIL ENGINES



Model		KDI 1903TCR	KDI 2504TCR
<b>Engine specs</b>	4 stroke diesel with cylinder in line	•	•
	Liquid cooling	•	•
	4 valves per cylinder	•	•
	In crankcase camshaft, gear train driven	•	•
	Pushrod - rocker arms timing with hydraulic tappets	•	•
	Cast iron crankcase with bed-plate	•	•
	Closed crankcase ventilation system	•	•
	High pressure common rail (2000 bar)	•	•
	Electronic engine management	•	•
	Waste-gate turbocharger	•	•
	Charge-air cooling	(•)	(•)
<b>Technical features</b>	Cylinder	3	4
	Bore (mm)	88	88
	Stroke (mm)	102	102
	Engine displ (cm <sup>3</sup> )	1861	2482
	Injection system	DI	DI
	Injection Equipment	Common rail (2000 bar)	Common rail (2000 bar)
<b>Performance</b>	Emission compliance	TIER 4 Final / STAGE III B	TIER 4 Final / STAGE III B
	Max power (IFN - ISO 3046 and ISO 14396) (kW@rpm)	42@2400 - 2600	55.4@2400 - 2600
	Max torque (IFN - ISO 3046 and ISO 14396) (Nm@rpm)	225@1500	300@1500
	Low-end torque (Nm@1000 rpm)	172	242
<b>Fuel economy</b>	Best point (g/kWh)	215	210
	Max power (g/kWh@2400 rpm)	237	226
<b>Startability</b>	Unaided (°C)	down to -19	down to -19
	Aided* (°C)	below -19	below -19
	* Manifold grid heater		
<b>Fuel compatibility</b>	EN 590	•	•
	No 1 Diesel (US) - ASTM D 975-09 B - Grade 1-D S 15	•	•
	No 2 Diesel (US) - ASTM D 975-09 B - Grade 2-D S 15	•	•
	Arctic EN 590/ASTM D 975-09 B (No petroleum added)	•	•
<b>Service features</b>	Oil/filter change interval std/synthetic (hr)	500-750*	500-750*
	Valve adjustment	—	—
	Alternator belt replacement	36mth	36mth
	Coolant change	24 mth	24 mth
	Oil consumption (% fuel)	<0.1	<0.1
	* according to operating conditions		
<b>Physical characteristics</b>	H×L×W (fan excluded) (mm)	726×598.3×530	719.5×704.3×523.2
	Weight (kg)	233	267
	Daily service points - positions	1 side service	1 side service
	Ambient operating temps (°C)	-40 to +50	-40 to +50
	Gradeability-all round (continuous) (deg)	25	25
	Gradeability-all round (intermittent-1min) (deg)	35	35
<b>Cooling &amp; lubrication</b>	Heat rejection to coolant (includes oil cooler) (kW)	32	44
	Cooling fluid: 50/50 water/antifreeze	•	•
	Oil type	SAE 5W 30 low SAPS EURO 6 API CJ-4	SAE 5W 30 low SAPS EURO 6 API CJ-4
<b>Vibration</b>	Max engine excitation at mounting locations	5g	5g
<b>Auxiliary PTOs (3rd &amp; 4th optional)</b>	Max torque (Nm)	100	100
	Drive ratio	1.23 times engine speed	1.23 times engine speed
	Provision for a double Gr:2 tandem hydraulic pump	•	•